

PHYSICAL SCIENCES

Name & Signature of the Invigilator

PAPER-II OMR Answer Sheet No. :

--	--	--	--	--

SEPT-1602

Roll No. :

--	--	--	--	--

(in figures as in Hall Ticket)

Roll Number in words :

Time : 1.15 Hours]

No. of Printed Pages : 20

[Maximum Marks : 100

Instructions for the Candidates

- Write your Roll Number in the space provided on the top of this page.
- This paper consists of **fifty (50)** multiple choice type of questions. All questions are compulsory.
- At the commencement of examination, the question booklet will be given to you. In the first 5 minutes, you are requested to open the booklet and compulsorily examine it as below :
 - To have access to the Question Booklet, tear off the paper seal on the edge of this cover page. Do not accept a booklet without sticker seal and do not accept an open booklet.
 - Tally the number of pages and number of questions in the booklet with the information printed on the cover page. Faulty booklets due to pages/questions missing or duplicate or not in serial order or any other discrepancy should be got replaced immediately by a correct booklet from the invigilator within the period of 5 minutes. Afterwards, neither the Question Booklet will be replaced nor any extra time will be given.
 - After this verification is over, the Test Booklet Number should be entered on the OMR Answer Sheet and the OMR Answer Sheet Number should be entered on this Test Booklet.
- Each item has four alternative responses marked (A), (B), (C) and (D). You have to darken the oval as indicated below on the correct response against each item.
Example : (A) ● (B) ○ (C) ○ (D) ○ where (B) is the correct response.
- Your responses to the items are to be indicated on the OMR Answer Sheet under Paper – II only. If you mark your response at any place other than in the oval in the OMR Answer Sheet, it will not be evaluated.
- Read instructions given inside carefully.
- Rough Work is to be done in the end of this booklet.
- If you write your Name, Roll Number, Phone Number or put any mark on any part of the OMR Answer Sheet, except for the space allotted for the relevant entries, which may disclose your identity, or use abusive language or employ any other unfair means, such as change of response by scratching or using white fluid, you will render yourself liable to disqualification.
- You have to return the original OMR Answer Sheet to the invigilator at the end of the examination compulsorily and must not carry it with you outside the Examination Hall. You are however, allowed to carry original question booklet and duplicate copy of OMR Answer Sheet on conclusion of examination.
- Use only Blue/Black Ball point pen.
- Use of any calculator or log table etc., is prohibited.
- There shall be no negative marking.
- In case of any discrepancy in the English and Gujarati versions of questions, English version will be taken as final.

પરીક્ષાર્થીઓ માટે સૂચનાઓ :

- આ પાનાની ટોચ પર દર્શાવેલી જગ્યામાં તમારો રોલ નંબર લખો.
- આ પ્રશ્નપત્રમાં અલ્ટ્રાવૈકલિપક ઉત્તરો ધરાવતા પચાસ (૫૦) પ્રશ્નો આપેલા છે. બધાજ પ્રશ્નો ફરજિયાત છે.
- પરીક્ષાની શરૂઆતમાં આપને પ્રશ્નપુસ્તિકા આપવામાં આવશે. પ્રથમ પાંચ (૫) મિનિટ દરમિયાન તમારે પ્રશ્નપુસ્તિકા ખોલી અને ફરજિયાતપણે નીચે મુજબ પરીક્ષણ કરવું :
 - પ્રશ્નપુસ્તિકાનો વપરાશ કરવા માટે આ કવર પૃષ્ઠની ધાર પર આપેલ સીલ સ્ટીકર ફાડી નાખો. કોઈપણ સંજોગોમાં સીલ સ્ટીકર વગરની કે ખુલ્લી પ્રશ્નપુસ્તિકા સ્વીકારશો નહીં.
 - કવર પૃષ્ઠ પર છપાવેલ નિર્દેશાનુસાર પ્રશ્નપુસ્તિકાના પ્રશ્નો, પૃષ્ઠો અને સંખ્યાને બરાબર ચકાસી લો. ખામીયુક્ત પ્રશ્નપુસ્તિકા કે જેમાં પ્રશ્નો/પૃષ્ઠો ઓછા હોય, બંધ વાર છપાયા હોય, અનુક્રમમાં અથવા અન્ય કોઈ ફરક હોય અર્થાત કોઈપણ સંજોગોમાં ખામીયુક્ત પ્રશ્નપુસ્તિકા સ્વીકારશો નહીં. અને જો ખામીયુક્ત પ્રશ્નપુસ્તિકા મળી હોય તો નિરીક્ષક પાસેથી તુરંત જ બીજી સારી પ્રશ્નપુસ્તિકા મેળવી લેવી. આ માટે ઉમેદવારને પાંચ (૫) મિનિટનો સમયગાળો આપવામાં આવશે. પછી થી, પ્રશ્નપુસ્તિકા બદલવામાં આવશે નહીં કે કોઈ વધારાનો સમયગાળો આપવામાં આવશે નહીં.
 - આ ચકાસણી સમાપ્ત થાય પછી, પ્રશ્નપુસ્તિકાનો નંબર OMR જવાબ પત્રક પર લખવો અને OMR જવાબ પત્રકનો નંબર પ્રશ્નપુસ્તિકા પર લખવો.
- પ્રત્યેક પ્રશ્ન માટે ચાર જવાબ વિકલ્પ (A), (B), (C) અને (D) આપવામાં આવેલ છે. તમારે સાચા જવાબના ઓવલ (oval) ને નીચે આપેલ ઉદાહરણ મુજબ પેનથી ભરીને સંપૂર્ણ કરવાનું રહેશે.
ઉદાહરણ : (A) ● (B) ○ (C) ○ (D) ○ કે જ્યાં (B) સાચો જવાબ છે.
- આ પ્રશ્નપુસ્તિકાના પ્રશ્નો ના જવાબ અલગથી આપવામાં આવેલ OMR જવાબ પત્રકમાં પેપર-II લખેલ વિભાગમાં જ અંકિત કરવા. જો આપ OMR જવાબ પત્રકમાં આપેલ ઓવલ (oval) સિવાય અન્ય સ્થાને જવાબ અંકિત કરશો તો તે જવાબનું મૂલ્યાંકન કરવામાં આવશે નહીં.
- અંદર આપેલ સૂચનાઓ ધ્યાનપૂર્વક વાંચો.
- કાંઈ કામ (Rough Work) પ્રશ્નપુસ્તિકાના અન્તિમ પૃષ્ઠ પર કરવું.
- જો આપ OMR જવાબ પત્રક નિયત જગ્યા સિવાય અન્ય કોઈપણ સ્થાને, આપનું નામ, રોલ નંબર, ફોન નંબર અથવા એવું કોઈ ચિન્હ કે જેનાથી તમારી ઓળખ જાણી શકે, અંકિત કરશો અથવા અબદ્ધ ભાષાનો પ્રયોગ કરો, અથવા અન્ય કોઈ અનુચિત સાધનોનો ઉપયોગ કરો, જેમ કે અંકિત કરી દીધેલ જવાબ ભૂંસી નાખવો કે સફેદ શાહીનો ઉપયોગ કરી બદલશો તો આપને પરીક્ષા માટે અયોગ્ય જાહેર થઈ શકો છો.
- પરીક્ષા સમય પુરો થઈ ગયા બાદ ઓરીજનલ OMR જવાબ પત્રક જે તે નિરીક્ષકને ફરજિયાત સોંપી દેવું અને કોઈ પણ સંજોગોમાં તે પરીક્ષાખંડની બહાર લઈ જવું નહીં. પરીક્ષા પૂર્ણ થયા બાદ ઉમેદવાર ઓરીજનલ પ્રશ્નપુસ્તિકા અને OMR જવાબ પત્રકની ડુપ્લિકેટ કોપી પોતાની સાથે લઈ જઈ શકે છે.
- માત્ર કાળી/ભૂરી બોલ પોઈન્ટ પેન વાપરવી.
- કેલક્યુલેટર અને અન્ય ઈલેક્ટ્રોનિક યંત્રોનો ઉપયોગ કરવાની મનાઈ છે.
- મોટા જવાબ માટે નકારાત્મક ગુણાંકન પ્રમાણ નથી.
- પ્રશ્નપુસ્તિકાના કોઈ પ્રશ્નમાં અનુવાદ અંગે કોઈ વિવાદ/મતભેદ જણાય તો અંગ્રેજી વર્ઝન ધોગ્ય ગણાશે.

SEAL

LOGARITHMS

	0	1	2	3	4	5	6	7	8	9	Mean Differences								
												1	2	3	4	5	6	7	8
10	0000	0043	0086	0128	0170	0212	0253	0294	0334	0374	4	8	12	17	21	25	29	33	37
11	0414	0453	0492	0531	0569	0607	0645	0682	0719	0755	4	8	11	15	19	23	26	30	34
12	0792	0828	0864	0899	0934	0969	1004	1038	1072	1106	3	7	10	14	17	21	24	28	31
13	1139	1173	1206	1239	1271	1303	1335	1367	1399	1430	3	6	10	13	16	19	23	26	29
14	1461	1492	1523	1553	1584	1614	1644	1673	1703	1732	3	6	9	12	15	18	21	24	27
15	1761	1790	1818	1847	1875	1903	1931	1959	1987	2014	3	6	8	11	14	17	20	22	25
16	2041	2068	2095	2122	2148	2175	2201	2227	2253	2279	3	5	8	11	13	16	18	21	24
17	2304	2330	2355	2380	2405	2430	2455	2480	2504	2528	2	5	7	10	12	15	17	20	22
18	2553	2577	2601	2625	2648	2672	2695	2718	2742	2765	2	5	7	9	12	14	16	19	21
19	2768	2810	2833	2856	2878	2900	2923	2945	2967	2989	2	4	7	9	11	13	15	18	20
20	3010	3032	3054	3075	3096	3118	3139	3160	3181	3201	2	4	6	8	11	13	15	17	19
21	3222	3243	3263	3284	3304	3324	3345	3365	3385	3404	2	4	6	8	10	12	14	16	18
22	3424	3444	3464	3483	3502	3522	3541	3560	3579	3598	2	4	6	8	10	12	14	15	17
23	3617	3636	3655	3674	3692	3711	3729	3747	3765	3784	2	4	6	7	9	11	13	15	17
24	3802	3820	3838	3856	3874	3892	3909	3927	3945	3962	2	4	5	7	9	11	12	14	16
25	3979	3997	4014	4031	4048	4065	4082	4099	4116	4133	2	3	5	7	9	10	12	14	15
26	4150	4168	4183	4200	4216	4232	4249	4265	4281	4298	2	3	5	7	8	10	11	13	15
27	4314	4330	4346	4362	4378	4393	4409	4425	4440	4456	2	3	5	6	8	9	11	13	14
28	4472	4487	4502	4518	4533	4548	4564	4579	4594	4609	2	3	5	6	8	9	11	12	14
29	4624	4639	4654	4669	4683	4698	4713	4728	4742	4757	1	3	4	6	7	9	10	12	13
30	4771	4786	4800	4814	4829	4843	4857	4871	4886	4900	1	3	4	6	7	9	10	11	13
31	4914	4928	4942	4955	4969	4983	4997	5011	5024	5038	1	3	4	6	7	8	10	11	12
32	5051	5065	5079	5092	5106	5119	5132	5145	5159	5172	1	3	4	5	7	8	9	11	12
33	5185	5198	5211	5224	5237	5250	5263	5276	5289	5302	1	3	4	5	6	8	9	10	12
34	5315	5328	5340	5353	5366	5378	5391	5403	5416	5428	1	3	4	5	6	8	9	10	11
35	5441	5453	5465	5478	5490	5502	5514	5527	5539	5551	1	2	4	5	6	7	9	10	11
36	5563	5575	5587	5599	5611	5623	5635	5647	5658	5670	1	2	4	5	6	7	8	10	11
37	5682	5694	5705	5717	5728	5740	5752	5763	5775	5786	1	2	3	5	6	7	8	9	10
38	5798	5809	5821	5832	5843	5855	5866	5877	5888	5899	1	2	3	5	6	7	8	9	10
39	5911	5922	5933	5944	5955	5966	5977	5988	5999	6010	1	2	3	4	5	7	8	9	10
40	6021	6031	6042	6053	6064	6075	6085	6096	6107	6117	1	2	3	4	5	6	8	9	10
41	6128	6138	6149	6160	6170	6180	6191	6201	6212	6222	1	2	3	4	5	6	7	8	9
42	6232	6243	6253	6263	6274	6284	6294	6304	6314	6325	1	2	3	4	5	6	7	8	9
43	6335	6345	6355	6365	6375	6385	6395	6405	6415	6425	1	2	3	4	5	6	7	8	9
44	6435	6444	6454	6464	6474	6484	6493	6503	6513	6522	1	2	3	4	5	6	7	8	9
45	6532	6542	6551	6561	6571	6580	6590	6599	6609	6618	1	2	3	4	5	6	7	8	9
46	6628	6637	6646	6656	6665	6675	6684	6693	6702	6712	1	2	3	4	5	6	7	7	8
47	6721	6730	6739	6749	6758	6767	6776	6785	6794	6803	1	2	3	4	5	5	6	7	8
48	6812	6821	6830	6839	6848	6857	6866	6875	6884	6893	1	2	3	4	4	5	6	7	8
49	6902	6911	6920	6928	6937	6946	6955	6964	6972	6981	1	2	3	4	4	5	6	7	8
50	6990	6998	7007	7016	7024	7033	7042	7050	7059	7067	1	2	3	3	4	5	6	7	8
51	7076	7084	7093	7101	7110	7118	7126	7135	7143	7152	1	2	3	3	4	5	6	7	8
52	7160	7168	7177	7185	7193	7202	7210	7218	7226	7235	1	2	2	3	4	5	6	7	7
53	7243	7251	7259	7267	7275	7284	7292	7300	7308	7316	1	2	2	3	4	5	6	6	7
54	7324	7332	7340	7348	7356	7364	7372	7380	7388	7396	1	2	2	3	4	5	6	6	7

No.
 $x = 3.14159$
 $e = 2.71828$

log
 0.46715
 0.43429

$\ln x = \log_e x = (1/M) = \log_{10} x$
 $\log x = \log_{10} x = M \log_e x$

No.
 $(1/M) = 2.30259$
 $M = 0.43429$

log
 0.36222
 1.63778

LOGARITHMS

	0	1	2	3	4	5	6	7	8	9	Mean Differences								
											1	2	3	4	5	6	7	8	9
55	7404	7412	7419	7427	7435	7443	7451	7459	7466	7474	1	2	2	3	4	5	5	6	7
56	7482	7490	7497	7505	7513	7520	7528	7536	7543	7551	1	2	2	3	4	5	5	6	7
57	7569	7666	7574	7582	7589	7597	7604	7612	7619	7627	1	2	2	3	4	5	5	6	7
58	7634	7642	7649	7657	7664	7672	7679	7686	7694	7701	1	1	2	3	4	4	5	6	7
59	7709	7716	7723	7731	7738	7745	7752	7760	7767	7774	1	1	2	3	4	4	5	6	7
60	7782	7789	7796	7803	7810	7818	7825	7832	7839	7846	1	1	2	3	4	4	5	6	6
61	7853	7860	7868	7875	7882	7889	7896	7903	7910	7917	1	1	2	3	4	4	5	6	6
62	7924	7931	7938	7945	7952	7959	7966	7973	7980	7987	1	1	2	3	3	4	5	6	6
63	7993	8000	8007	8014	8021	8028	8035	8041	8048	8055	1	1	2	3	3	4	5	5	6
64	8062	8069	8076	8082	8089	8096	8102	8109	8116	8122	1	1	2	3	3	4	5	5	6
65	8129	8136	8142	8149	8156	8162	8169	8176	8182	8189	1	1	2	3	3	4	5	5	6
66	8195	8202	8209	8215	8222	8228	8235	8241	8248	8254	1	1	2	3	3	4	5	5	6
67	8261	8267	8274	8280	8287	8293	8299	8306	8312	8319	1	1	2	3	3	4	5	5	6
68	8326	8331	8338	8344	8351	8357	8363	8370	8376	8382	1	1	2	3	3	4	4	5	6
69	8388	8395	8401	8407	8414	8420	8426	8432	8439	8445	1	1	2	2	3	4	4	5	6
70	8451	8457	8463	8470	8476	8482	8488	8494	8500	8506	1	1	2	2	3	4	4	5	6
71	8513	8519	8525	8531	8537	8543	8549	8555	8561	8567	1	1	2	2	3	4	4	5	5
72	8573	8579	8585	8591	8597	8603	8609	8615	8621	8627	1	1	2	2	3	4	4	5	5
73	8633	8639	8645	8651	8657	8663	8669	8675	8681	8686	1	1	2	2	3	4	4	5	5
74	8692	8698	8704	8710	8716	8722	8727	8733	8739	8745	1	1	2	2	3	4	4	5	5
75	8751	8756	8762	8768	8774	8779	8785	8791	8797	8802	1	1	2	2	3	3	4	5	5
76	8808	8814	8820	8825	8831	8837	8842	8848	8854	8859	1	1	2	2	3	3	4	5	5
77	8866	8871	8876	8882	8887	8893	8899	8904	8910	8915	1	1	2	2	3	3	4	4	5
78	8921	8927	8932	8938	8943	8949	8954	8960	8965	8971	1	1	2	2	3	3	4	4	5
79	8976	8982	8987	8993	8998	9004	9009	9015	9020	9025	1	1	2	2	3	3	4	4	5
80	9031	9036	9042	9047	9053	9058	9063	9069	9074	9079	1	1	2	2	3	3	4	4	5
81	9085	9090	9096	9101	9106	9112	9117	9122	9128	9133	1	1	2	2	3	3	4	4	5
82	9138	9143	9149	9154	9159	9165	9170	9175	9180	9186	1	1	2	2	3	3	4	4	5
83	9191	9196	9201	9206	9212	9217	9222	9227	9232	9238	1	1	2	2	3	3	4	4	5
84	9243	9248	9253	9258	9263	9269	9274	9279	9284	9289	1	1	2	2	3	3	4	4	5
85	9294	9299	9304	9309	9315	9320	9325	9330	9335	9340	1	1	2	2	3	3	4	4	5
86	9346	9350	9355	9360	9365	9370	9375	9380	9385	9390	1	1	2	2	3	3	4	4	5
87	9395	9400	9405	9410	9415	9420	9425	9430	9435	9440	0	1	1	2	2	3	3	4	4
88	9445	9450	9455	9460	9465	9469	9474	9479	9484	9489	0	1	1	2	2	3	3	4	4
89	9494	9499	9504	9509	9513	9518	9523	9528	9533	9538	0	1	1	2	2	3	3	4	4
90	9542	9547	9552	9557	9562	9566	9571	9576	9581	9586	0	1	1	2	2	3	3	4	4
91	9590	9595	9600	9605	9609	9614	9619	9624	9628	9633	0	1	1	2	2	3	3	4	4
92	9638	9643	9647	9652	9657	9661	9666	9671	9675	9680	0	1	1	2	2	3	3	4	4
93	9685	9689	9694	9699	9703	9708	9713	9717	9722	9727	0	1	1	2	2	3	3	4	4
94	9731	9736	9741	9745	9750	9754	9759	9763	9768	9773	0	1	1	2	2	3	3	4	4
95	9777	9782	9786	9791	9795	9800	9805	9809	9814	9818	0	1	1	2	2	3	3	4	4
96	9823	9827	9832	9836	9841	9845	9850	9854	9859	9863	0	1	1	2	2	3	3	4	4
97	9868	9872	9877	9881	9886	9890	9894	9899	9903	9908	0	1	1	2	2	3	3	4	4
98	9912	9917	9921	9926	9930	9934	9939	9943	9948	9952	0	1	1	2	2	3	3	4	4
99	9956	9961	9965	9969	9974	9978	9983	9987	9991	9996	0	1	1	2	2	3	3	4	4

p	1	2	3	4	5	6	7	8	9	10
$\log e^p$	0.4343	0.8686	1.3029	1.7372	2.1715	2.6058	3.0401	3.4744	3.9087	4.3429
$\log e^{-p}$	1.5657	1.1314	2.6971	2.2628	3.8285	3.3942	4.9599	4.5256	4.0913	5.6571

ANTILOGARITHMS

	0	1	2	3	4	5	6	7	8	9	Mean Differences								
											1	2	3	4	5	6	7	8	9
.00	1000	1002	1005	1007	1009	1012	1014	1016	1019	1021	0	0	1	1	1	1	2	2	2
.01	1023	1026	1028	1030	1033	1035	1038	1040	1042	1045	0	0	1	1	1	1	2	2	2
.02	1047	1050	1052	1054	1057	1059	1062	1064	1067	1069	0	0	1	1	1	1	2	2	2
.03	1072	1074	1076	1079	1081	1084	1086	1089	1091	1094	0	0	1	1	1	1	2	2	2
.04	1096	1099	1102	1104	1107	1109	1112	1114	1117	1119	0	1	1	1	1	1	2	2	2
.05	1122	1125	1127	1130	1132	1135	1138	1140	1143	1146	0	1	1	1	1	1	2	2	2
.06	1148	1151	1153	1156	1159	1161	1164	1167	1169	1172	0	1	1	1	1	1	2	2	2
.07	1175	1178	1180	1183	1186	1189	1191	1194	1197	1199	0	1	1	1	1	1	2	2	2
.08	1202	1205	1208	1211	1213	1216	1219	1222	1225	1227	0	1	1	1	1	1	2	2	3
.09	1230	1233	1236	1239	1242	1245	1247	1250	1253	1256	0	1	1	1	1	1	2	2	3
.10	1259	1262	1265	1268	1271	1274	1276	1279	1282	1285	0	1	1	1	1	1	2	2	3
.11	1288	1291	1294	1297	1300	1303	1306	1309	1312	1315	0	1	1	1	1	1	2	2	3
.12	1318	1321	1324	1327	1330	1334	1337	1340	1343	1346	0	1	1	1	1	1	2	2	3
.13	1349	1352	1355	1358	1361	1365	1368	1371	1374	1377	0	1	1	1	1	1	2	2	3
.14	1380	1384	1387	1390	1393	1396	1400	1403	1406	1409	0	1	1	1	1	1	2	2	3
.15	1413	1416	1419	1422	1426	1429	1432	1435	1439	1442	0	1	1	1	1	1	2	2	3
.16	1445	1449	1452	1455	1459	1462	1466	1469	1472	1476	0	1	1	1	1	1	2	2	3
.17	1479	1483	1486	1489	1493	1496	1500	1503	1507	1510	0	1	1	1	1	1	2	2	3
.18	1514	1517	1521	1524	1528	1531	1535	1538	1542	1545	0	1	1	1	1	1	2	2	3
.19	1549	1552	1556	1560	1563	1567	1570	1574	1578	1581	0	1	1	1	1	1	2	2	3
.20	1585	1589	1592	1596	1600	1603	1607	1611	1614	1618	0	1	1	1	1	1	2	2	3
.21	1622	1626	1629	1633	1637	1641	1644	1648	1652	1656	0	1	1	1	1	1	2	2	3
.22	1660	1663	1667	1671	1675	1679	1683	1687	1690	1694	0	1	1	1	1	1	2	2	3
.23	1698	1702	1706	1710	1714	1718	1722	1726	1730	1734	0	1	1	1	1	1	2	2	3
.24	1738	1742	1746	1750	1754	1758	1762	1766	1770	1774	0	1	1	1	1	1	2	2	3
.25	1778	1782	1786	1791	1795	1799	1803	1807	1811	1816	0	1	1	1	1	1	2	2	3
.26	1820	1824	1828	1832	1837	1841	1845	1849	1854	1858	0	1	1	1	1	1	2	2	3
.27	1862	1866	1871	1875	1879	1884	1888	1892	1897	1901	0	1	1	1	1	1	2	2	3
.28	1905	1910	1914	1919	1923	1928	1932	1936	1941	1945	0	1	1	1	1	1	2	2	3
.29	1950	1954	1959	1963	1968	1972	1977	1982	1986	1991	0	1	1	1	1	1	2	2	3
.30	1996	2000	2004	2009	2014	2018	2023	2028	2032	2037	0	1	1	1	1	1	2	2	3
.31	2042	2046	2051	2056	2061	2065	2070	2075	2080	2084	0	1	1	1	1	1	2	2	3
.32	2089	2094	2099	2104	2109	2113	2118	2123	2128	2133	0	1	1	1	1	1	2	2	3
.33	2138	2143	2148	2153	2158	2163	2168	2173	2178	2183	0	1	1	1	1	1	2	2	3
.34	2188	2193	2198	2203	2208	2213	2218	2223	2228	2234	1	1	2	2	3	3	4	4	5
.35	2239	2244	2249	2254	2259	2265	2270	2275	2280	2286	1	1	2	2	3	3	4	4	5
.36	2291	2296	2301	2307	2312	2317	2323	2328	2333	2339	1	1	2	2	3	3	4	4	5
.37	2344	2350	2355	2360	2366	2371	2377	2382	2388	2393	1	1	2	2	3	3	4	4	5
.38	2399	2404	2410	2415	2421	2427	2432	2438	2444	2449	1	1	2	2	3	3	4	4	5
.39	2455	2460	2466	2472	2477	2483	2489	2495	2500	2506	1	1	2	2	3	3	4	4	5
.40	2512	2518	2523	2529	2535	2541	2547	2553	2559	2564	1	1	2	2	3	3	4	4	5
.41	2570	2576	2582	2588	2594	2600	2606	2612	2618	2624	1	1	2	2	3	3	4	4	5
.42	2630	2636	2642	2649	2655	2661	2667	2673	2679	2685	1	1	2	2	3	3	4	4	5
.43	2692	2698	2704	2710	2716	2723	2729	2735	2742	2748	1	1	2	2	3	3	4	4	5
.44	2754	2761	2767	2773	2780	2786	2793	2799	2805	2812	1	1	2	2	3	3	4	4	5
.45	2818	2825	2831	2838	2844	2851	2858	2864	2871	2877	1	1	2	2	3	3	4	4	5
.46	2884	2891	2897	2904	2911	2917	2924	2931	2938	2944	1	1	2	2	3	3	4	4	5
.47	2951	2958	2965	2972	2979	2985	2992	2999	3006	3013	1	1	2	2	3	3	4	4	5
.48	3020	3027	3034	3041	3048	3055	3062	3069	3076	3083	1	1	2	2	3	3	4	4	5
.49	3090	3097	3105	3112	3119	3126	3133	3141	3148	3155	1	1	2	2	3	3	4	4	5

Antilogarithm Chart continue on page No. 17

PHYSICAL SCIENCES

PAPER-II

Note : This paper contains **FIFTY (50)** multiple-choice/Assertion and Reasoning matching questions, each question carrying **TWO (2)** marks. Attempt **All** questions.

1. $f(x) = 1$ for $0 < x < \pi$
 $= 0$ for $-\pi < x < 0$

when $f(x)$ is represented by corresponding Fourier series, then the value of the Fourier series at $x = 0$ is :

(A) $\frac{1}{2}$ (B) 0

(C) 1 (D) $\frac{1}{\sqrt{2}}$

2. If $\bar{A} = -\frac{1}{3}\hat{i} + \mu\hat{j}$ is a unit vector, then the value of ' μ ' can be :

(A) $\frac{2}{3}$ (B) $-\frac{2\sqrt{2}}{3}$

(C) $\frac{8}{9}$ (D) $\frac{+4}{3}$

3. What is the value of $\iiint \vec{\nabla} \cdot \vec{F} \, dx \, dy \, dz$ over the region $x^2 + y^2 + z^2 \leq 16$, where :

$$\vec{F} = (x^2 + y^2 + z^2)(x\hat{i} + y\hat{j} + z\hat{k})$$

(A) 4π (B) $\frac{4^6\pi}{5}$

(C) Zero (D) $\frac{3\pi}{5}4^6$

4. If a coin is tossed 5 times in succession, the probability of getting at least one head is :
- (A) $\frac{1}{32}$ (B) $\frac{5}{32}$
(C) $\frac{1}{2}$ (D) $\frac{31}{32}$
5. Hermite functions are useful in the study of :
- (A) Electrostatic problem solving multipolar charge distribution
(B) Hydrogen atom in quantum mechanics
(C) Linear Harmonic Oscillator in quantum mechanics
(D) Periodic potential problem in crystallinity of solids
6. Two circular discs D_1 and D_2 of same thickness and same mass have different densities, ρ_1 and ρ_2 with $\rho_1 > \rho_2$. They are rotated around an axis passing through centre and \perp to the disks :
- (A) They have same moment of inertia
(B) Moment of inertia of $D_1 >$ Moment of inertia of D_2
(C) Moment of inertia of $D_1 <$ Moment of inertia of D_2
(D) Moment of inertia of D_1 /Moment of inertia of $D_2 = \frac{\rho_1}{\rho_2}$
7. In the theory of small oscillations, generally the dependency of potential energy on the displacement of particle from equilibrium position is :
- (A) Linear (B) Quadratic
(C) Cubical (D) Inverse square

8. The unit of Hamiltonian is the unit of :
- (A) Angular momentum (B) Planck's constant
(C) Force (D) Torque
9. A pendulum bob of mass 'm' is held taut in a horizontal position and then released. What is the tension in the string when both of reaches its lowest position :
- (A) $\sqrt{2}$ mg (B) 3 mg
(C) 2 mg (D) mg
10. Reduced mass of a two body system depends on :
- (A) Position of the centre of mass \vec{R}
(B) Relative coordinate $\vec{r} = \vec{r}_1 - \vec{r}_2$
(C) On both R and r
(D) Neither on R nor on r
11. Electric field variation for a uniformly charged sphere of radius R with constant charge density ρ :
- (A) varies as $\frac{1}{r}$ for $r < R$ (B) varies as r for $r < R$
(C) is zero for $r < R$ (D) is constant for $r < R$

12. Which of the following is *false* ?
- (A) An electron moving from point A to B in a straight line at uniform speed radiates
 - (B) Proton moving in linear accelerator radiates
 - (C) Proton moving in a circular orbit at constant speed radiates
 - (D) Electron while moving through a potential difference of 2500 volts in a straight line radiates
13. Which of the following equations relating to electric field \vec{E} and magnetic field \vec{B} rules out the possibility of an isolated magnetic monopoles :
- (A) $\vec{\nabla} \cdot \vec{B} = 0$
 - (B) $\vec{\nabla} \cdot \vec{E} = 0$
 - (C) $\vec{\nabla} \times \vec{E} = -\frac{\partial \vec{B}}{\partial t}$
 - (D) $\vec{\nabla} \times \vec{B} = \mu_0 \vec{J}$
14. A battery of EMF ξ and internal resistance 'r' is connected to variable load resistance R. Power delivered to load resistance 'R' is maximised by varying 'R', the battery loses the energy at the rate of :
- (A) $\xi^2/4r$
 - (B) ξR
 - (C) $\xi^2/2r$
 - (D) $\frac{2\xi^2}{R}$
15. A charged capacitor 'C' is connected in series with an inductor 'L'. When the displacement current is zero, the energy of LC circuit is :
- (A) stored entirely in its electric field
 - (B) distributed equally among its electric and magnetic fields
 - (C) radiated out of the circuit
 - (D) stored entirely in its magnetic field

16. The uncertainty relation applies to :
- (A) X and P_X only
 (B) Any pair of dynamical variables
 (C) A pair of dynamical variables which do not commute
 (D) A pair of dynamical variables which commute
17. Zero point energy of a three-dimensional harmonic oscillator in quantum mechanics is :
- (A) Zero
 (B) $\frac{\hbar\omega}{2}$
 (C) $\frac{h}{\omega}$
 (D) $\frac{3}{2}\hbar\omega$
18. The magnitude of orbital angular momentum with quantum number ' l ' is :
- (A) lh
 (B) $\sqrt{l(l+1)}\hbar$
 (C) $l(l+1)\hbar$
 (D) $\sqrt{(l+\frac{1}{2})(l-\frac{1}{2})}\hbar$
19. The dimension of wave function ψ in three-dimensional space is :
- (A) $L^{-3/2}$
 (B) L^{-3}
 (C) dimensionless
 (D) L^3
20. The degeneracy of a level with principal quantum number ' n ', in a Hydrogen atom is :
- (A) n^2
 (B) $2n^2$
 (C) n
 (D) \sqrt{n}

21. Which of the following is *not* an example of second order phase transition ?
- (A) Liquid He^I to liquid He^{II}
 (B) Ferromagnetic to paramagnetic phase transition
 (C) Ice converts into water
 (D) Superconducting state to normal state transition at T_c
22. In a Brownian motion, if 'D' is diffusivity of Brownian particles and 't' is diffusion time, then, the dimension of (Dt) is :
- (A) $M^0L^2T^0$ (B) $M^0L^1T^{-1}$
 (C) $M^0L^{-2}T^1$ (D) $M^0L^{-2}T^0$
23. Superfluidity is a phenomenon connected to :
- (A) Pauli's exclusion principle
 (B) Bose Einstein condensation
 (C) Debye's theory of specific heat
 (D) Heisenberg's uncertainty principle
24. The partition function of a single gas molecule is Z_0 . The partition function of 'N' such non-interacting identical gas molecules is :
- (A) NZ_0 (B) Z_0^N
 (C) $\frac{Z_0^N}{N!}$ (D) $Z_0 \ln N$

25. The ratio of C_P/C_V for diatomic molecular gas :
- (A) is always $5/3$
 - (B) increases continuously with increase in temperature
 - (C) changes in steps at particular values of temperature
 - (D) decreases continuously with increase in temperature
26. What should be the minimum number of bits required to convert analog voltage having full range 0 to 2 volts to be converted to digital with a resolution of 4 mV ?
- (A) 9
 - (B) 500
 - (C) 8
 - (D) 256
27. In 8085 the number of maximum input and output devices that can be connected is :
- (A) 64
 - (B) 512
 - (C) 256
 - (D) 65536
28. For high efficiency optoelectronic devices the preferred semiconductor is :
- (A) Direct and narrow band gap
 - (B) Indirect and narrow band gap
 - (C) Direct and wide band gap
 - (D) Indirect and wide band gap

29. The following circuit is known as :

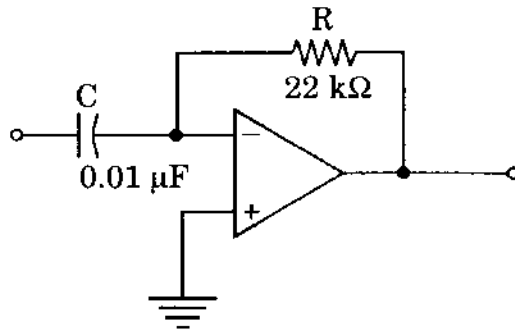

- (A) Inverting Amplifier (B) Differentiator
(C) Integrator (D) Subtractor

30. What is the output when number 59 is converted to hexadecimal ?

- (A) 59 (B) 3B
(C) 0101 1001 (D) 0011 1011

31. Low resistance can be measured by :

- (A) Kelvin's double bridge (B) Wein bridge
(C) De-Sauty's bridge (D) Rayleigh's bridge

32. Which of the following pressure gauges is used for measuring pressure in the range of 10^{-10} Torr ?

- (A) Pirani Gauge (B) Penning Gauge
(C) McLeod Gauge (D) Hot Cathode Gauge

33. At low value of magnetic field the transverse magnetoresistance is :
- (A) Directly proportional to the field
 - (B) Inversely proportional to the field
 - (C) Proportional to the square of the field
 - (D) Inversely proportional to the square of the field
34. A workshop suprintendent measures temperature of a boiler. He will use :
- (A) Resistance Thermometer
 - (B) Radiation Pyrometer
 - (C) Thermocouple
 - (D) Goniometer
35. For two resistances $R_1 = 100 \pm 0.1 \Omega$ and $R_2 = 50 \pm 0.03 \Omega$ find the value of equivalent resistance when they are connected in parallel :
- (A) $50 \pm 0.068 \Omega$
 - (B) $150 \pm 0.13 \Omega$
 - (C) $33.33 \pm 0.017 \Omega$
 - (D) $33.33 \pm 0.068 \Omega$
36. Laser light is not :
- (A) Non-coherent
 - (B) Intense
 - (C) Coherent
 - (D) Unidirectional

37. Pauli's exclusion principle states that :
- (A) Two electrons cannot have all the quantum numbers same
 - (B) Two electrons can have all the quantum numbers same
 - (C) $\Delta x \Delta p \geq \frac{\hbar}{2}$
 - (D) Particles with integer and half-integer spin cannot exist in the same state
38. The Bohr model gives the value for ionization potential of Li^{2+} ion as :
- (A) 13.6 eV
 - (B) 54.4 eV
 - (C) 40.8 eV
 - (D) 122.4 eV
39. The normal Zeeman effect is :
- (A) Not a confirmation of space quantization
 - (B) Observed only in atoms with an even number of electrons
 - (C) Observed only in atoms with an odd number of electrons
 - (D) A confirmation of space quantization
40. Arrange energy differences involved in electronic transitions, vibrational transitions and rotational transitions in ascending order :
- (A) Vibrational, Rotational, Electronic
 - (B) Rotational, Vibrational, Electronic
 - (C) Electronic, Vibrational, Rotational
 - (D) Rotational, Electronic, Vibrational

41. The number of nearest neighbours for mon-atomic F.C.C. structure is :
- (A) 4 (B) 6
(C) 8 (D) 12
42. Bragg's law in terms of reciprocal lattice vector \vec{G} is :
- (A) $2\vec{K} \cdot \vec{G} + K^2 = 0$ (B) $2\vec{K} \cdot \vec{G} + G^2 = 0$
(C) $G^2 + 4K^2 = 0$ (D) $2G^2 + 2K^2 = 0$
43. For a superconductor, the Meissner effect demonstrates its :
- (A) Infinite resistivity (B) Infinite conductivity
(C) Perfect diamagnetism (D) Perfect ferromagnetism
44. The angle between {100} direction with {111} direction in a cubic lattice is :
- (A) acute (B) obtuse
(C) 0° , parallel (D) 90° , perpendicular
45. The attractive part of the van der Waal's interaction potential varies as r^n where n is :
- (A) -2 (B) -4
(C) -6 (D) -12

46. Binding energy per nucleon for the nuclei ${}^4\text{He}$, ${}^{56}\text{Fe}$, ${}^{197}\text{Au}$ and ${}^{235}\text{U}$ are given as BE_1 , BE_2 , BE_3 and BE_4 respectively. Which of the following is *correct* order ?
- (A) $\text{BE}_1 < \text{BE}_2 < \text{BE}_3 < \text{BE}_4$ (B) $\text{BE}_1 > \text{BE}_2 > \text{BE}_3 > \text{BE}_4$
 (C) $\text{BE}_2 < \text{BE}_3 < \text{BE}_4 < \text{BE}_1$ (D) $\text{BE}_2 > \text{BE}_3 > \text{BE}_4 > \text{BE}_1$
47. The quark structure of Δ^{++} is :
- (A) uuu (B) udu
 (C) sss (D) ddd
48. A thermal neutron having speed v collides with ${}^{235}\text{U}$ nucleus. The absorption cross-section is proportional to :
- (A) v^{-1} (B) v
 (C) $v^{1/2}$ (D) $v^{-1/2}$
49. The decay chain of the nucleus ${}^{238}_{92}\text{U}$ involves eight α -decays and six β -decays. The final nucleus at the end of the process will have :
- (A) $Z = 82, A = 206$ (B) $Z = 84, A = 224$
 (C) $Z = 86, A = 206$ (D) $Z = 76, A = 200$
50. Nuclear forces are :
- (A) Spin dependent and have no non-central component
 (B) Spin dependent and have a non-central component
 (C) Spin independent and have no non-central component
 (D) Spin independent and have a non-central component

ANTILOGARITHMS

	0	1	2	3	4	5	6	7	8	9	Mean Differences								
											1	2	3	4	5	6	7	8	9
.50	3162	3170	3177	3184	3192	3199	3206	3214	3221	3228	1	1	2	3	4	4	5	6	7
.51	3236	3243	3251	3258	3266	3273	3281	3289	3296	3304	1	2	2	3	4	5	5	6	7
.52	3311	3319	3327	3334	3342	3350	3357	3365	3373	3381	1	2	2	3	4	5	5	6	7
.53	3388	3396	3404	3412	3420	3428	3436	3443	3451	3459	1	2	2	3	4	5	6	6	7
.54	3467	3475	3483	3491	3499	3508	3516	3524	3532	3540	1	2	2	3	4	5	6	6	7
.55	3548	3556	3565	3573	3581	3589	3597	3606	3614	3622	1	2	2	3	4	5	6	7	7
.56	3631	3639	3648	3656	3664	3673	3681	3690	3698	3707	1	2	3	3	4	5	6	7	8
.57	3715	3724	3733	3741	3750	3758	3767	3776	3784	3793	1	2	3	3	4	5	6	7	8
.58	3802	3811	3819	3828	3837	3846	3855	3864	3873	3882	1	2	3	4	4	5	6	7	8
.59	3890	3899	3908	3917	3926	3936	3945	3954	3963	3972	1	2	3	4	5	5	6	7	8
.60	3981	3990	3999	4009	4018	4027	4036	4046	4055	4064	1	2	3	4	5	6	6	7	8
.61	4074	4083	4093	4102	4111	4121	4130	4140	4150	4159	1	2	3	4	5	6	7	8	9
.62	4169	4178	4188	4198	4207	4217	4227	4236	4246	4256	1	2	3	4	5	6	7	8	9
.63	4266	4276	4285	4295	4305	4315	4325	4335	4345	4355	1	2	3	4	5	6	7	8	9
.64	4365	4375	4385	4395	4406	4416	4426	4436	4446	4457	1	2	3	4	5	6	7	8	9
.65	4467	4477	4487	4498	4508	4519	4529	4539	4550	4560	1	2	3	4	5	6	7	8	9
.66	4571	4581	4592	4603	4613	4624	4634	4645	4656	4667	1	2	3	4	5	6	7	8	10
.67	4677	4688	4699	4710	4721	4732	4742	4753	4764	4775	1	2	3	4	5	7	8	9	10
.68	4786	4797	4808	4819	4831	4842	4853	4864	4875	4887	1	2	3	4	6	7	8	9	10
.69	4898	4909	4920	4932	4943	4955	4966	4977	4989	5000	1	2	3	5	6	7	8	9	10
.70	5012	5023	5035	5047	5058	5070	5082	5093	5105	5117	1	2	4	5	6	7	8	9	11
.71	5129	5140	5152	5164	5176	5188	5200	5212	5224	5236	1	2	4	5	6	7	8	10	11
.72	5248	5260	5272	5284	5297	5309	5321	5333	5346	5358	1	2	4	5	6	7	9	10	11
.73	5370	5383	5395	5408	5420	5433	5446	5458	5470	5483	1	3	4	5	6	8	9	10	11
.74	5495	5508	5521	5534	5546	5559	5572	5585	5598	5610	1	3	4	5	6	8	9	10	12
.75	5623	5636	5649	5662	5675	5689	5702	5715	5728	5741	1	3	4	5	7	8	9	10	12
.76	5754	5768	5781	5794	5808	5821	5834	5848	5861	5875	1	3	4	5	7	8	9	11	12
.77	5888	5902	5916	5929	5943	5957	5970	5984	5998	6012	1	3	4	5	7	8	10	11	12
.78	6026	6039	6053	6067	6081	6095	6109	6124	6138	6152	1	3	4	6	7	8	10	11	13
.79	6166	6180	6194	6209	6223	6237	6252	6266	6281	6295	1	3	4	6	7	9	10	11	13
.80	6310	6324	6339	6353	6368	6383	6397	6412	6427	6442	1	3	4	6	7	9	10	12	13
.81	6457	6471	6486	6501	6516	6531	6546	6561	6577	6592	2	3	5	6	8	9	11	12	14
.82	6607	6622	6637	6653	6668	6683	6699	6714	6730	6745	2	3	5	6	8	9	11	12	14
.83	6761	6776	6792	6808	6823	6839	6855	6871	6887	6902	2	3	5	6	8	9	11	13	14
.84	6918	6934	6950	6966	6982	6998	7015	7031	7047	7063	2	3	5	6	8	10	11	13	15
.85	7079	7096	7112	7129	7145	7161	7178	7194	7211	7228	2	3	5	7	8	10	12	13	15
.86	7244	7261	7278	7295	7311	7328	7345	7362	7379	7396	2	3	5	7	8	10	12	13	15
.87	7413	7430	7447	7464	7482	7499	7516	7534	7551	7568	2	3	5	7	9	10	12	14	16
.88	7586	7603	7621	7638	7656	7674	7691	7709	7727	7745	2	4	5	7	9	11	12	14	16
.89	7762	7780	7798	7816	7834	7852	7870	7889	7907	7925	2	4	5	7	9	11	13	14	16
.90	7943	7962	7980	7998	8017	8035	8054	8072	8091	8110	2	4	6	7	9	11	13	15	17
.91	8128	8147	8166	8185	8204	8222	8241	8260	8279	8299	2	4	6	8	9	11	13	15	17
.92	8318	8337	8356	8375	8395	8414	8433	8453	8472	8492	2	4	6	8	10	12	14	15	17
.93	8511	8531	8551	8570	8590	8610	8630	8650	8670	8690	2	4	6	8	10	12	14	16	18
.94	8710	8730	8750	8770	8790	8810	8831	8851	8872	8892	2	4	6	8	10	12	14	16	18
.95	8913	8933	8954	8974	8995	9016	9036	9057	9078	9099	2	4	6	8	10	12	15	17	19
.96	9120	9141	9162	9183	9204	9226	9247	9268	9290	9311	2	4	6	8	11	13	15	17	19
.97	9333	9354	9376	9397	9419	9441	9462	9484	9506	9528	2	4	7	9	11	13	15	17	20
.98	9550	9572	9594	9616	9638	9661	9683	9705	9727	9750	2	4	7	9	11	13	16	18	20
.99	9772	9795	9817	9840	9863	9886	9908	9931	9954	9977	2	5	7	9	11	14	16	18	20

ROUGH WORK