

Signature of Invigilators

1. ....

2. ....

## PHYSICAL SCIENCE Paper III

Roll No.

(In figures as in Admit Card)

Roll No. ....

(In words)

**JY-04/2**

Name of the Areas/Section (if any).....

Time Allowed : 2½ Hours]

[Maximum Marks : 200

### Instructions for the Candidates

1. Write your Roll Number in the space provided on the top of this page.
2. Write name of your Elective/Section if any.
3. Answer to short answer/essay type questions are to be written in the space provided below each question or after the questions in test booklet itself. No additional sheets are to be used.
4. Read instructions given inside carefully.
5. Last page is attached at the end of the test booklet for rough work.
6. If you write your name or put any special mark on any part of the test booklet which may disclose in any way your identity, you will render yourself liable to disqualification.
7. Use of calculator or any other Electronics Devices are prohibited.
8. There is no negative marking.
9. You should return the test booklet to the invigilator at the end of the examination and should not carry any paper outside the examination hall.

### પરીક્ષાર્થીઓ માટે સૂચનાઓ :

૧. આ પૃષ્ઠના ઉપલા ભાગે આપેલી જગ્યામાં તમારી ક્રમાંક સંખ્યા (રોલ નંબર) લખો.
૨. તમે જે વિકલ્પનો ઉત્તર આપો તેનો સ્પષ્ટ નિર્દેશ કરો.
૩. ટૂંક નોંધ કે નિબંધ પ્રકારના પ્રશ્નોના ઉત્તર દરેક પ્રશ્નની નીચે આપેલી જગ્યામાં જ લખો. વધારાના કોઈ કાગળનો ઉપયોગ કરશો નહીં.
૪. અંદર આપેલી સૂચનાઓ ધ્યાનથી વાંચો.
૫. આ ઉત્તર પોથીને અંતે આપેલું પૃષ્ઠ કાચા કામ માટે છે.
૬. આ ઉત્તર પોથીમાં ક્યાંય પણ તમારી ઓળખ કરાવી દે એવી રીતે તમારું નામ કે કોઈ ચોક્કસ નિશાની કરી હશે તો તમે આ પરીક્ષા માટે ગેરલાયક સાબીત થશો.
૭. કેલક્યુલેટર અથવા ઈલેક્ટ્રોનિક્સ સાધનો જેવાનો ઉપયોગ કરવો નહીં.
૮. નકારાત્મક ગુણાંક પદ્ધતિ નથી.
૯. પ્રશ્નપત્ર લખાઈ રહે એટલે આ ઉત્તર પોથી તમારા નિરીક્ષકને આપી દેવી. પરીક્ષાખંડની બહાર કોઈ પણ પ્રશ્નપત્ર લઈ જવું નહીં.

### FOR OFFICE USE ONLY Marks Obtained

Question Number	Marks Obtained	Question Number	Marks Obtained	Question Number	Marks Obtained
1.		20.			
2.		21.			
3.		22.			
4.		23.			
5.		24.			
6.		25.			
7.		26.			
8.					
9.					
10.					
11.					
12.					
13.					
14.					
15.					
16.					
17.					
18.					
19.					

Total Marks Obtained.....

Signature of the co-ordinator.....

(Evaluation)

SEAL



## PHYSICAL SCIENCE

### PAPER-III

*Note :* (i) Part A consists of 10 questions of 10 marks each. All questions are compulsory.

(ii) Part B consists of 16 questions of 25 marks each. Attempt any *four* questions from Part B.

#### PART A

- (A) Define divergence and curl of a vector. Point out their significance in physics with illustrations.  
(B) What is meant by rank of a matrix ? Interpret unitary and Hermitian matrices and obtain eigenvalues of a matrix  $\begin{bmatrix} 0 & 1 \\ 1 & 0 \end{bmatrix}$ .
- State the Lorentz transformations and using these derive the velocity addition rule.
- A particle of mass  $m$  moves under a conservative force with potential energy  $V(x) = \frac{cx}{x^2 + a^2}$ , where  $c$  and  $a$  are constants. Find the positions of stable equilibrium and the period of small oscillations about it.
- What is meant by gauge transformation in electromagnetic potentials ? What are different gauges used ? Obtain the second order differential equations for potentials using Lorentz gauge.
- Write the Maxwell's equations in differential form and obtain corresponding integral forms of these equations.

6. Applying Heisenberg's uncertainty principle estimate the ground state energies of linear harmonic oscillator and Hydrogen atom.
7. Define central potential. Using Born approximation obtain differential and total scattering cross sections for any spherically symmetric potential.
8. How did the Einstein theory explain the failure of Dulong and Petit law ? Discuss the merits and demerits of Einsteins quantum theory of specific heats of solids.
9. Describe four probe method for measurement of resistivity  $\rho$  with its correction factors.
10. Explain the quantization process used in an A/D converter. Draw a quantized error  $e(t)$  waveform for any given function  $x(t)$ .

### PART B

11. (A) Explain working of a full-wave rectifier using the waveforms of  $v_p$ ,  $i_{D1}$ ,  $i_{D2}$ ,  $i_L$  and  $v_L$ . Calculate its load voltage  $v_L$  across the load resistor  $R_L$ .
- (B) A silicon diode with its  $i$ - $v$  characteristic  $i_D = I_0[e^{qV_D/mKT} - 1]$ . Calculate  $r_d$ , the dynamic resistance of the diode, with appropriate derivation for  $r_d$  given that  $V_T = 25\text{mV}$  at  $T = 300^\circ\text{K}$  and  $I_{DQ}$  (at operating point) = 10mA.
- (C) What is PIV (peak inverse voltage) of a rectifying diode ? Why you need it to know ? Explain.

12. (A) Explain how a transistor can be used to realise a logical NOT gate. Find the value of  $R_b$  and  $R_c$  in the following transistor circuit shown in figure. For  $I_{B \text{ sat}} = 100 \mu\text{A}$  and  $V_i = 5\text{V}$

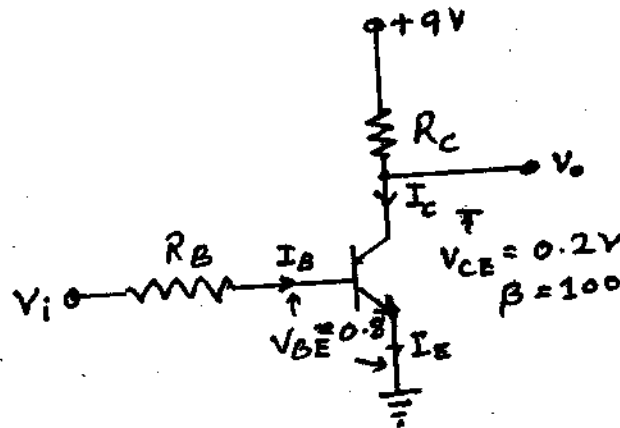

Fig.

- (B) "A bipolar junction transistor is a current controlled device rather than a voltage controlled device", Why ?
- (C) Derive for a given transistor.  $I_c = \frac{\beta}{1+\beta} I_E + I_{CBO}$  where  $\beta$  = current amplification factor of the transistor.
13. (A) Design a half adder and a full adder circuits.
- (B) Design a logic circuit which gives a '1' output when two of the three input A, B and C are '1'. Realise the circuit using only NAND gates.
14. (A) Explain the properties of a negative feedback amplifier with appropriate derivations.

- (B) Show that the bandwidth of an amplifier can be increased by applying a negative feedback to the amplifier. Calculate the increase in the bandwidth by the feedback.
15. (A) State the main features of the fine structure in Hydrogen spectrum. What is hyperfine structure ?
- (B) Interpret the spectroscopic terms and selection rules. How the relativistic corrections could be incorporated ?
16. (A) Distinguish between LASER and MASER. Explain the physics of ESR and point out its applications.
- (B) Compare X-ray spectra with optical spectra. Deduce and discuss the Moseley's law.
17. (A) State and discuss the coupling schemes of quantum numbers of electrons in atoms with special reference to spectroscopy.
- (B) Compare the spectra of alkali metals with those of hydrogen atom. Interpret the double structure in alkali spectra and discuss the transition rules.
18. (A) Derive an expression for the Compton shift and discuss its dependency.
- (B) Describe Stern-Gerlach experiment and point out its important inferences.
19. Distinguish between primitive cell and unit cell. Describe the diamond structure. Give details about its co-ordination number, atomic radius and number of bonds present in diamond and angle between tetrahedral bonds of diamond.

20. Show that the group velocity for monoatomic lattice is given by :

$$Vg = \left( \frac{C_1 \cdot a^2}{M} \right)^{1/2} \cdot \cos\left(\frac{1}{2}\right)Ka.$$

Discuss the result by plotting Vg versus K curve and show for a monoatomic linear lattice of N atoms with nearest neighbour interactions. Show that the density of modes are :

$$D(\omega) = \frac{2M}{\pi} \cdot \frac{1}{(\omega_m^2 - \omega^2)^{1/2}}$$

where  $\omega_m$  is the maximum frequency,  $C_1$  is the force constant between adjacent planes.

21. Derive the classical Langevin formula for orbital diamagnetism and obtain an order or magnitude of the diamagnetic susceptibility per unit volume using the same.

State the Hund rules and apply them to find out the ground state and effective magneton numbers "p" for  $C_r^{2+}$  and  $C_r^{3+}$ . (Atomic number of Cr is 24).

22. Discuss the magnetization curves for Type -I and Type -II superconductors. Show that the London equation

$$j = - \frac{C}{4\pi\lambda_L^2} \cdot \vec{A} \text{ leads to Meissner effect through the penetration equation}$$

$$\nabla^2 \cdot B = \frac{B}{\lambda_L^2} \text{ where } \lambda_L = \left\{ \frac{mc^2}{4\pi ne^2} \right\}^{1/2} \text{ is London penetration depth.}$$

23. (A) How do you measure the radius of a nucleus ? Obtain an expression for the same. Show that the density of the nuclei is constant throughout the periodic table.

- (B) What is Quadrupole moment of a nucleus ? Show that it vanishes if the nuclear spin is less than '1'.
24. (A) What are magic numbers ? How do you produce them in the shell model of the nucleus ?
- (B) Discuss how a gamma ray is detected in a detector. How does it differ from the detection of a  $\beta$ -particle and a neutron ?
25. (A) How do you distinguish between 'fission' and 'fusion'. Give examples of each. Calculate the energy released in a spontaneous fission.
- (B) What are Fermi-Kurie plots ? Discuss their applications.
26. (A) Give the Gellmann-Nishijima classification of elementary particles. Explain the strangeness concept.
- (B) What is CPT Theorem ? Discuss the CPT invariance in different types of interaction.